

Data required to machine Drawtube Actuator

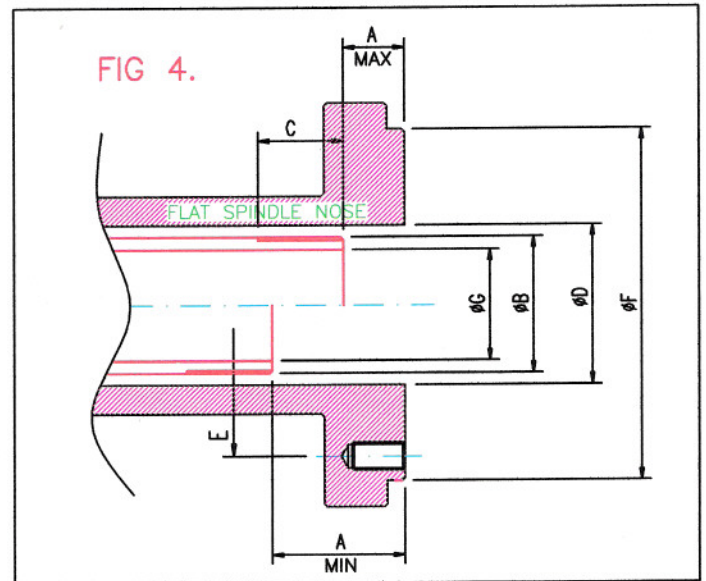
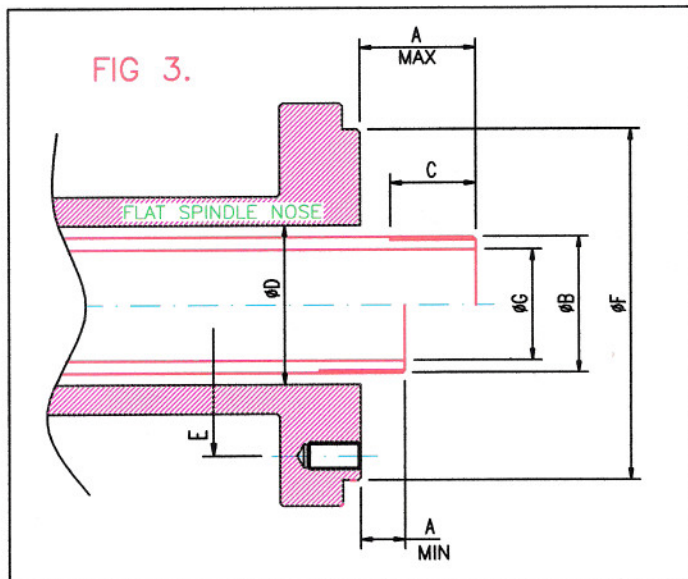
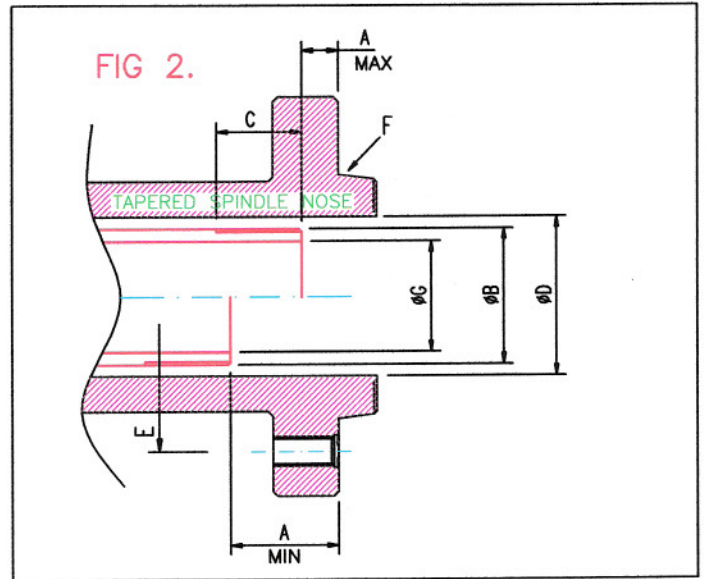
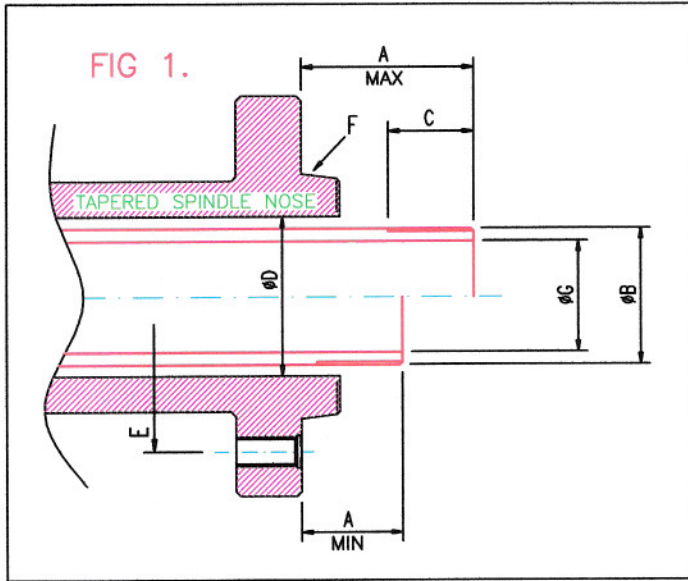

DO NOT SCALE - IF IN DOUBT ASK

UNLESS STATED ALL DIMENSIONS IN mm.

Circle which figure is required - FIG 1. FIG 2. FIG 3. FIG 4.

- A) Max forward position of Drawtube from spindle face
- A) Min backward position of Drawtube from spindle face
- B) Thread diameter, form & pitch. State if: L/H and if Internal
- C) Operative length of full thread
- D) Spindle bore diameter. State if tapered / recessed
- E) Fixing details, Thread size= P.C.D.= Spacing=
- F) American / DIN spindle mount, state type
- F) Straight spindle mount, state diameter
- G) Drawtube internal diameter



THAME ENGINEERING COMPANY LTD.

FIELD END, THAME ROAD,
LONG CRENDON, AYLESBURY,
BUCKS HP18 9EJ ENGLAND

FAX. +44 (0) 1844 201699

TEL. +44 (0) 1844 208050

E-mail sales@thame-eng.com

Web www.thame-eng.com